

**FAB-180**  
**SQUARE FIREPIT RING LINEAR**





Thank you for choosing our product. We appreciate your trust and we'll do our best to meet your expectations.

\*Read this manual carefully before using this product and save it for future reference.

# FAB-180

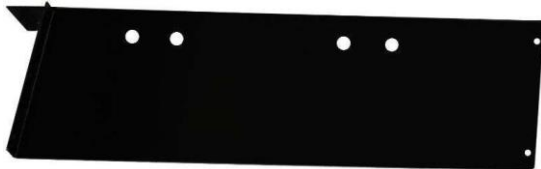
## SQUARE FIREPIT RING LINEAR

No.	PARTS	PHOTO	QTY.
A	PANEL		4 NOS.
B	HARDWARE SET		8 SET

- Do not throw away any package, before you make sure that all of the parts are there.
- To avoid scratching or damaging the finish, assemble the parts on a soft, clean surface.
- Keep children away from assembly area. This product has tiny pieces that children could swallow.
- When using this product, children should always be directly supervised by an adult.

### **ASSEMBLY**

**\*DO NOT FULLY TIGHTEN THE NUTS & BOLTS BEFORE ASSEMBLING THE ENTIRE PANEL.**

1. Set Panels (A) upright and align the holes on the sides of the panels, making sure the lip on the side of each panel will be on the inside of fire rim.
2. Connect the first 2 panels by hand-tightening 2x Bolts, 4x Washers and 2x Nuts.
3. Repeat Step 2 until all panels are connected.
4. Now, tighten all hardware.

# **FAB-180**

## **SQUARE FIREPIT RING LINEAR**

**NOTE:** You will notice 2-4mm space between the lips of two adjoining panels after assembly, which is the part of design and it is done to avoid panel matching complications hence the ease of fitment during assembling.

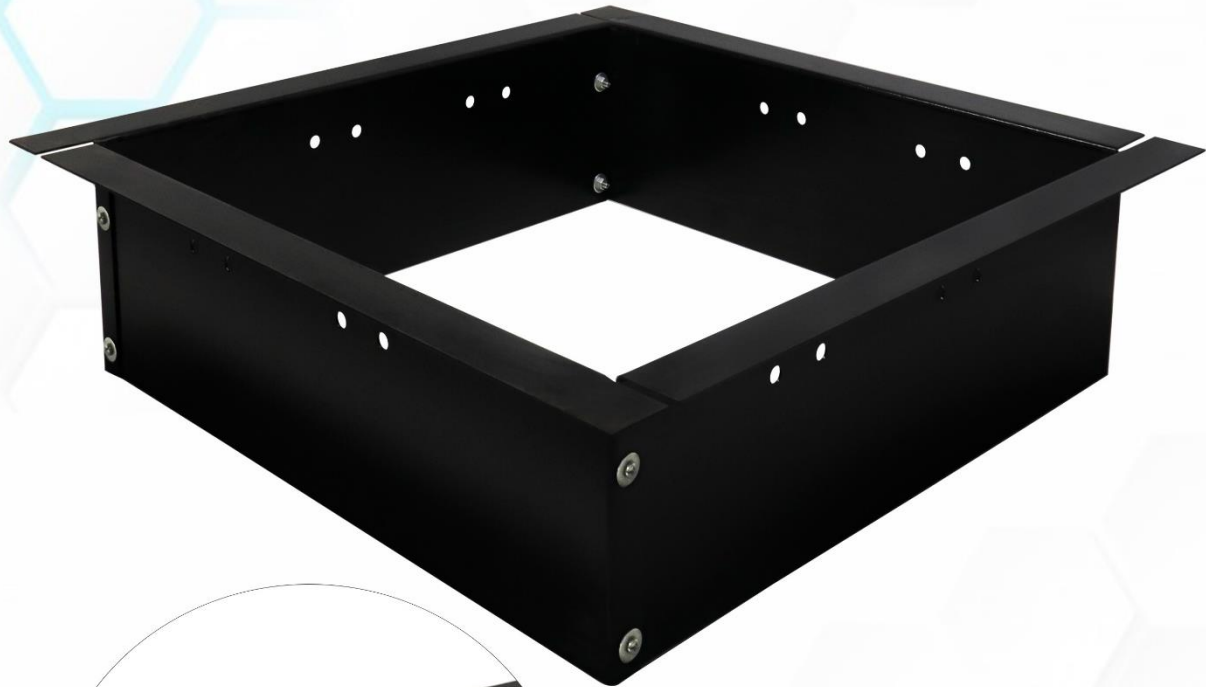

SPACE  
BETWEEN  
TWO PANEL

\* Simond Store cannot be held responsible for any damage or injury caused due to failure to follow the instruction or inappropriate use that is different than advised in the instructions for use.

**\*NOTE: Wear all safety instrument while assembling.**

**\*Please visit [www.simondstore.com](http://www.simondstore.com) for more product.**